

V33D-250 CLOSED LOOP

Variable displacement axial piston pump type V33D closed loop,
Peak pressure 420 bar

Tradition – Quality – Future

HIGH-PERFORMANCE PUMPS – MADE IN GERMANY



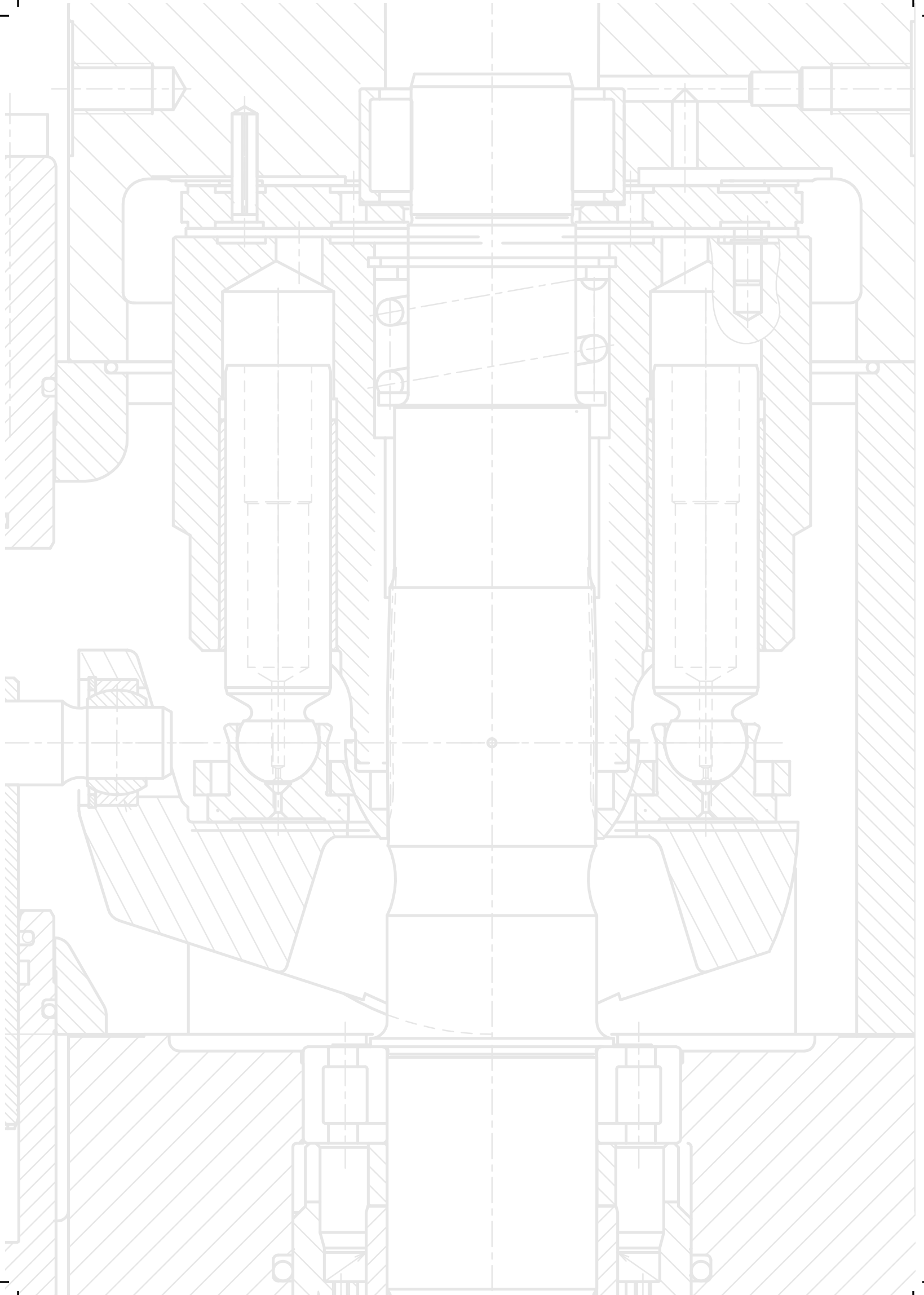

V33D Benefits

- ▶ High performance
- ▶ High drive speed
- ▶ High efficiency
- ▶ Low noise level
- ▶ Full range of controller
- ▶ Save directional valve, low pressure loss
- ▶ Save energy

Type code	4
Main characters closed loop	4
Tab. Controller one side displacement	5
Tab. Controller double side displacement	5
Technical data	5
History	6
What's new at V33D?	7
Technical structure of V33D-250	8/9
Applications	10/11

Type code

V33D	-250	R	D	G	N	-2	-1	-1	-2	-XX	/VH	-200	-350
													Pressure (bar)
													Torque setting (Nm/ KW at rpm)
													Controller see tab.
													HAWE InLine serial no.
													Setting unit
													1 unilateral setting unit with zero centering
													2 double-sided setting unit with zero centering & mechanical feedback
													Boost unit
													0 without intermediate flange and Feed- / Boost pump
													1 with intermediate flange and Feed- / Boost pump
													2 with intermediate flange
													Swash angle indicator
													0 none
													1 with indicator
													2 with pivoting angle pick up (elect. Sensor)
													Housing version
													1 no thru-shaft
													2 thru-shaft
													Seal
													N NBR
													V FKM
													C FKM suitable for HFC, see restrictions
													Flange version
													G DIN
													F SAE
													Shaft version
													D spline shaft
													K key shaft / Parallel key
													S spline shaft for SAE
													Rotation direction
													L counter-clockwise
													R clockwise
													Nominal size
													250
													Basic type

Main characters closed loop

Working principle	Variable displacement axial piston pump acc. to swash plate principle
Installation	Flange or bracket mounting
Direction of rotation	Clockwise / Counter-clockwise
Mounting position	Optional
Pressure fluid	Hydraulic fluid (DIN 51524 table 2 and 3); ISO VG 10 to 68 (DIN 51519) Viscosity range: min. 10; max. 1000 mm ² /s, optimal operation range: 10...35 mm ² /s Also suitable are biodegradable pressure fluids of the type HEES (synth. Ester) at operation temperatures up to +70°C.
Temperature	Ambient: -40 ... +60°C Fluid: -25...+80°C, pay attention to the viscosity range! Start temperature down to -40°C are allowable (Pay attention to the viscosity range during start!), as long as the operation temperature during consequent running is at least 20K (Kelvin) higher.
Filtration	19/17/14 conform to ISO 4406

Tab. Controller one side displacement:

Coding:	Discription:
...V	The controller V is used to control flow or speed in electronic or computer controlled systems. The V controller consists of a proportional solenoid acting on a servo valve that determines the position of the pump setting piston. The displacement of the pump is proportional to the current through the 24 V DC solenoid (about 250 - 750 mA). In order to minimize valve hysteresis, a pulse width modulated control signal of approx. 80-100 Hz frequency is recommended.
...VH	The VH is a flow controller. It is similar to the V controller but the control signal is hydraulic. The required signal range is 7...32 bar (215...725 psi). The pump displacement is determined by the control signal (refer to the diagram). Pilot pressure can be supplied either from the system through a pressure reducing valve, or from an auxiliary pump. The pump should provide a pulsating flow of about 100 Hz; gear pump with 7 teeth and 750 rpm if the system pressure is below 40...60 bar (580...870 psi) (depending on size) a small auxiliary pump is required to secure proper functioning of the controller.
...N	Pressure controller, adjustable directly at the pump. Pressure controller automatically maintains a constant system pressure independant of the required flow. Therefore it is suited for constant pressure systems, where differing flow is required or as efficient pressure limitation of the hydraulic system.
...P	Remotely adjustable pressure setting; the pressure is set with a pilot relief valve. The pilot relief can be positioned up to 20 m (60 ft) from the pump.
...L	The V33 D pump with power controller is used in applications with highly varying pressure demands and where it is important to protect the electric motor (engine) from overload. The controller limits the hydraulic power (at constant shaft speed) according to the ideal curve "pressure x flow = constant". The product of pressure and flow cannot exceed the pre-set power value. If, for example, the pressure doubles (at max power) the flow is automatically reduced by 50%.
...Lf	Means that there is a hydraulic displacement limiter included. The displacement can be increased by a pilot pressure from an outside source.
...Lf1	Means that there is a hydraulic displacement limiter included. The displacement can be reduced by a pilot pressure from an outside source.

Tab. Controller double side displacement:

Coding:	Discription:
...V	The controller V is used to control flow or speed in electronic or computer controlled systems. The V controller consists of a proportional solenoid acting on a servo valve that determines the position of the pump setting piston. The displacement of the pump is proportional to the current through the 24 V DC solenoid (about 250 - 750 mA). In order to minimize valve hysteresis, a pulse width modulated control signal of approx. 80-100 Hz frequency is recommended.
...VH	The VH is a flow controller. It is similar to the V controller but the control signal is hydraulic. The required signal range is 7...32 bar (215...725 psi). The pump displacement is determined by the control signal (refer to the diagram). Pilot pressure can be supplied either from the system through a pressure reducing valve, or from an auxiliary pump. The pump should provide a pulsating flow of about 100 Hz; gear pump with 7 teeth and 750 rpm is recommended. If the system pressure is below 40...60 bar (580...870 psi) (depending on size) a small auxiliary pump is required to secure proper functioning of the controller.
...N	Pressure controller, adjustable directly at the pump. Pressure controller automatically maintains a constant system pressure independant of the required flow. Therefore it is suited for constant pressure systems, where differing flow is required or as efficient pressure limitation of the hydraulic system.
...P	Remotely adjustable pressure setting; the pressure is set with a pilot relief valve. The pilot relief can be positioned up to 20 m (60 ft) from the pump.

technical data

Max. swash plate angle	± 17,5°
Min. inlet pressure (absolute) for Feed- and Servo pump abs	0,85 bar abs
Max. speed rpm	2000 rpm
Min. continuous speed rpm	500 rpm
Torque (theor.) at 1000 psi	414 Nm
Input power at 250 bar and 1450 rpm	180 kW
Weight (approx. kg) without Servo pump / with Servo pump	168 kg / 180 kg
Moment of inertia	0,085 kg/m ²
L10 bearing life at 250 bar/1450 rpm and max. displacement	23000 h
Max. dynamic torque	Spline shaft (D) input 3100 Nm Spline shaft (D) output 1550 Nm Key shaft (K) input 1550 Nm Spline shaft (S) input 1200 Nm Spline shaft (S) output 1000 Nm
Noise level at 250bar; 1450 rpm and max. displacement (measured in a semi-anechoic room according DIN ISO 4412/distance 1m	77 dB(A)

History

V33D pump closed loop: HAWE InLine is closing a gap

Axial piston pump from Berlin are well known for demanding heavy-duty and high pressure applications since decades. The enlargement of our product range to truck-mounted pumps has been our focus during the last years. Currently we are working on integrating medium pressure pumps and this makes our product range of variable axial-piston pumps quite complete – but so far only in open loop applications.



Nowadays our pumps are running with pressurized suction and mooring operation as well as bi-directional use, however the real operation in full size closed loop systems we know only from our past: pumps from Berlin have experienced as VOLVO-pumps various applications and installations in closed loop.

We built on this experience when it came to the demand on closing the gap in today product portfolio. Based on our actual serial design we do have **V33D-250 available now – our new pump for closed loop**. We combined leading technology from our heavy duty product range together with existing experience in Berlin and latest demand for pumps running in full four quadrant operation.



What's new at V33D?

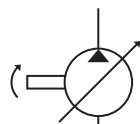
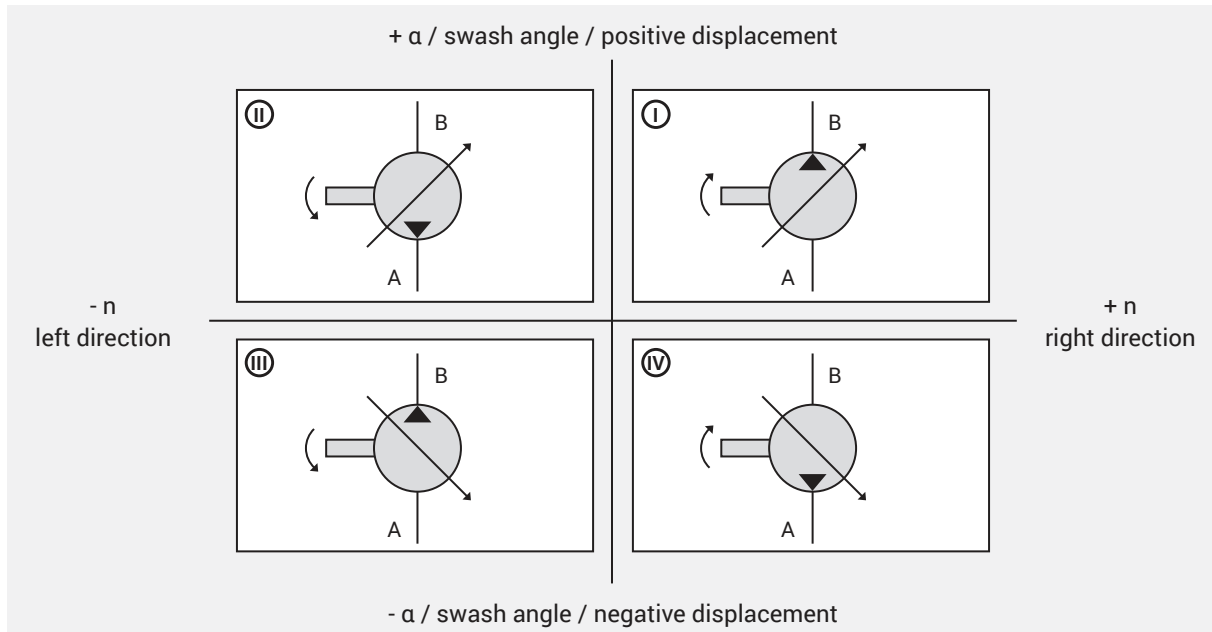

Ⓘ

open loop, one side closed loop

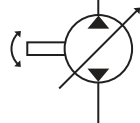

Ⓘ + Ⓙ

flow in both directions (SMAG, Wärtsilä)

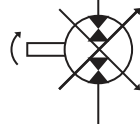

Ⓘ + Ⓧ

closed loop (drive system, steering gear, mooring)

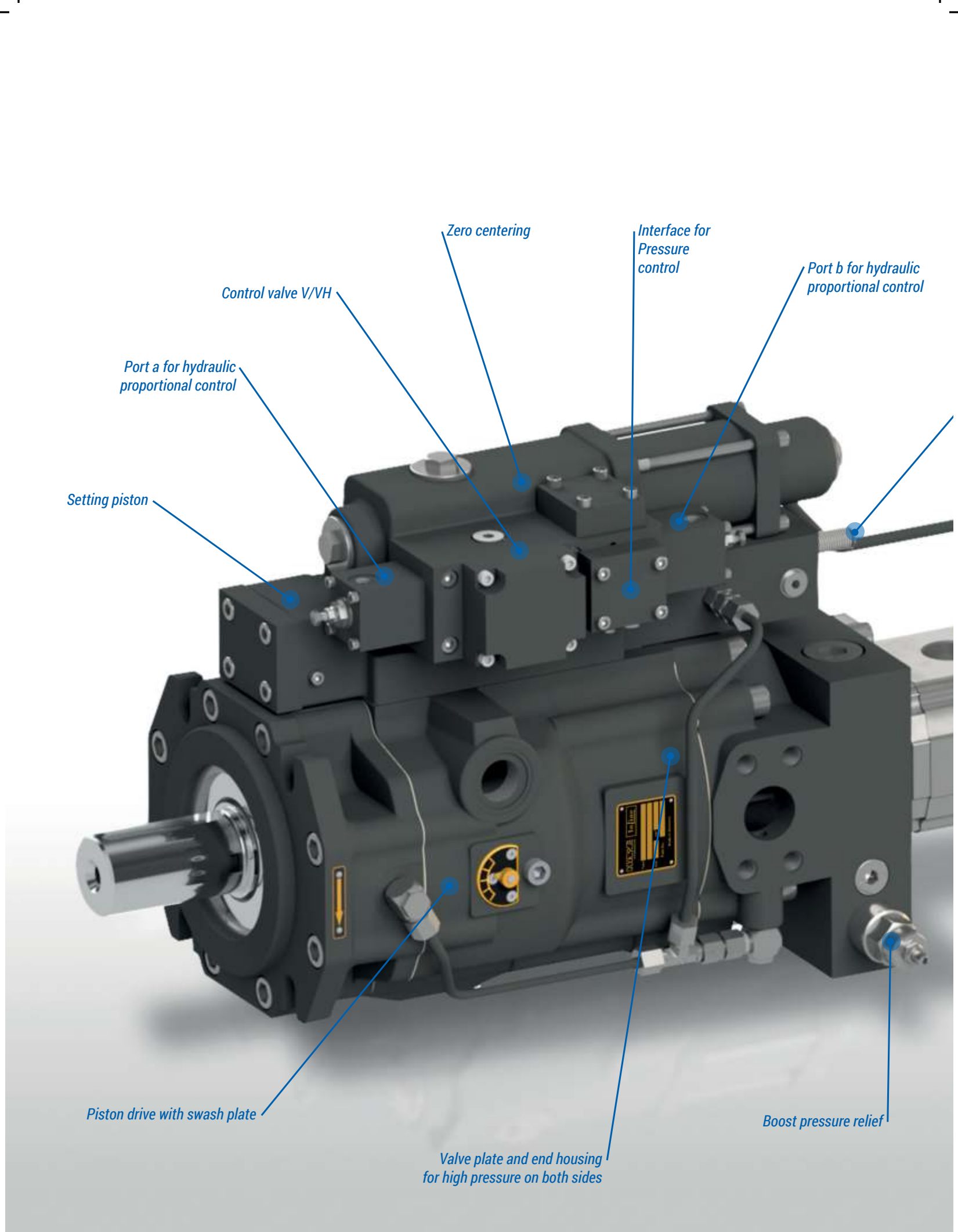

Control valve V/VH

Zero centering

Interface for Pressure control

Port b for hydraulic proportional control

Port a for hydraulic proportional control

Setting piston

Piston drive with swash plate

Valve plate and end housing for high pressure on both sides

Boost pressure relief

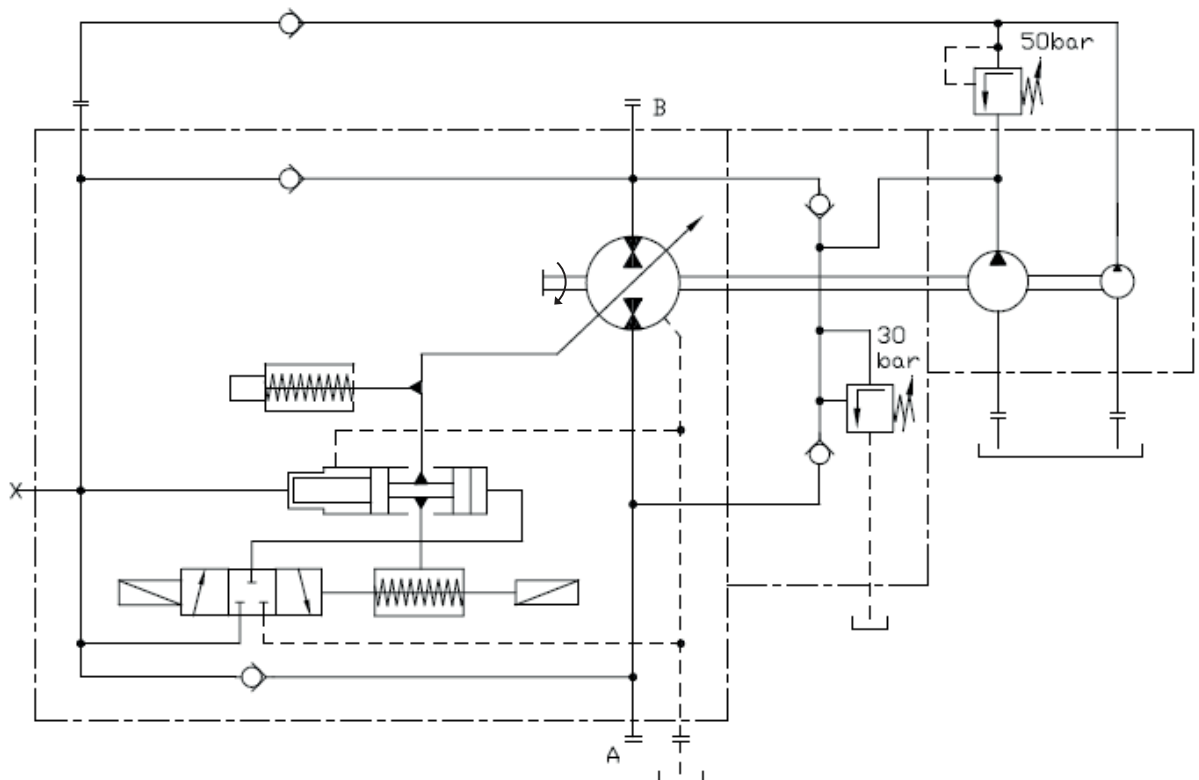

Stroke limiter for positive angles

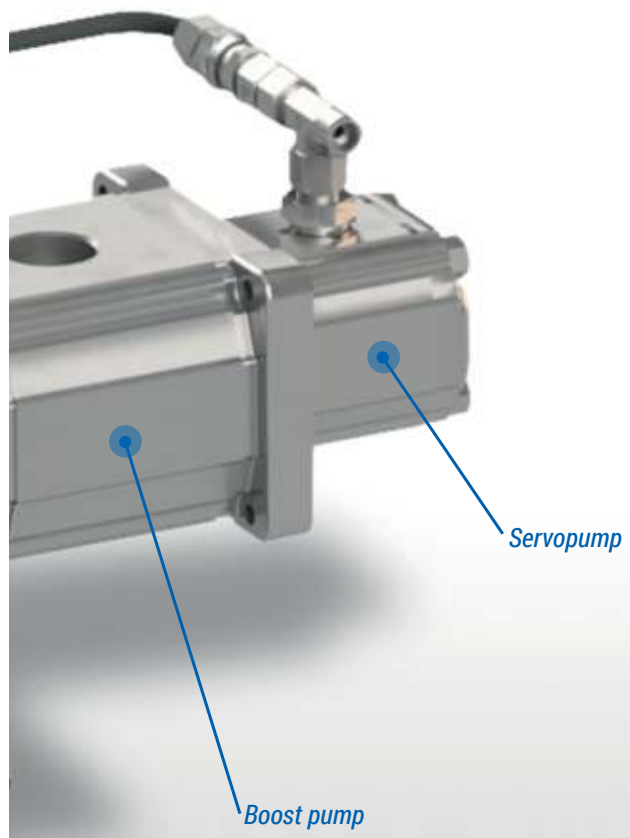

Version for one (right) direction of rotation

Applications



Pile driving machine



Coal mining



Mooring winch



Marine winches



Tunnel boring machine



Tunnel boring machine



Drilling machine



HAWE InLine Hydraulik GmbH

Sperenberger Straße 13
D-12277 Berlin

Tel: +49 (30) 72088 - 0
Fax: +49 (30) 72088 - 44

info@hawe-inline.com
www.hawe-inline.com



Member of the Hengli Group

